

Spare parts list  
Katalog náhradních dílů

GARUDAN®

**GC-3318-443-MH**



ANITA B, s.r.o.

Průmyslová 2453/7

680 01 Boskovice

Czech Republic

tel: +420 516 454 774

+420 516 453 496

fax: +420 516 452 751

e-mail: [info@anita.cz](mailto:info@anita.cz)

MODEL : GC - 3318 - 443 MH

CONTENT	PAGE
A. FRAME & MISCELLANEOUS COVER COMPONENTS -----	3-8
B. MAIN SHAFT & UPRIGHT SHAFT COMPONENTS -----	9-10
C. NEEDLE BAR & THREAD TAKE-UP LEVER COMPONENTS -----	11-12
D. NEEDLE BAR LOCKING MOTION MECHANISM COMPONENTS -----	13-14
E. UPPER FEED MECHANISM COMPONENTS -----	15-16
F. PRESSURE BAR & KNEE LIFTER COMPONENTS -----	17-22
G. LOWER FEED MECHANISM COMPONENTS -----	23-26
H. FEED ADJUSTMENT MECHANISM COMPONENTS -----	27-30
I. HOOK DRIVE SHAFT COMPONENTS -----	31-32
J. UPPER THREAD TENSION REGULATOR MECHANISM COMPONENTS -----	33-34
K. ACCESSORIES -----	35-36
L. GAUGE PARTS LIST -----	37

A. FRAME & MISCELLANEOUS COVER COMPONENTS (1/3)

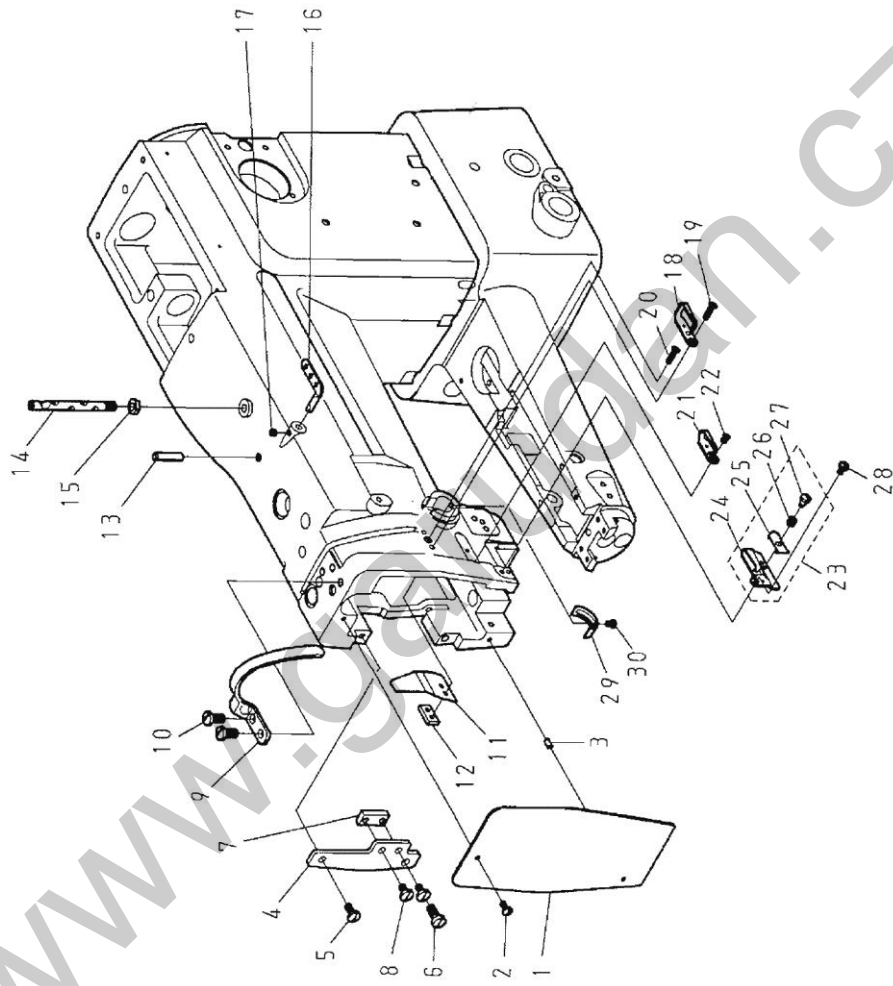

## A. FRAME &amp; MISCELLANEOUS COVER COMPONENTS (1/3)

REF.No	NOTE	Part No.	Name of Part	Remarks
1		8703111000	Face Plate	1
2		ZSB09017	Screw 9/64-40*8	1
3		YA035075	Pin	1
4		8233110900	Vibrating Presser Bar Guide	1
5		ZSB12006	Screw 3/16-28*10	1
6		ZSB15009	Screw 15/64-28*13	1
7		8233143700	Bell Crank Guide	1
8		ZSB12030	Screw 3/16-32*8	2
9		F1063-0A	Thread Take-up Lever Cover	1
10		ZSB15010	Screw 15/64-28*10	2
11		EJ1014-0A	Oil Guard Plate	1
12		EJ1017-0A	Spaser	1
13		YD060024	Oil Pipe	1
14		B1050-0A	Tread Guide	1
15		ZML06001	Nut	1
16		A1051-0A	Thread Guide	1
17		ZSA11007	Screw 11/64-40*7	1
18		C1052-0A	Thread Guide(Upper)	1
19		ZSC09021	Screw 9/64-40*13	1
20		ZSC09021	Screw 9/64-40*13	1
21		C1054-0A	Thread Guide(Center)	1
22		ZSC09009	Screw 9/64-40*6,5	1
23		8370311805	Thread Guide Asm.	1
24		EJ1055-0A	Thread Guide	(1)
25		EJ1056-0A	Guide Plate	(1)
26		EJ1057-0A	Spring	(1)
27		ZSG08003	Hinge Screw	(1)
28		ZSB09011	Screw 9/64-40*6,5	1
29		J1041-0A	Stooper	1
30		ZSB09005	Screw 9/64-40*5	1

A. FRAME & MISCELLANEOUS COVER COMPONENTS (2/3)

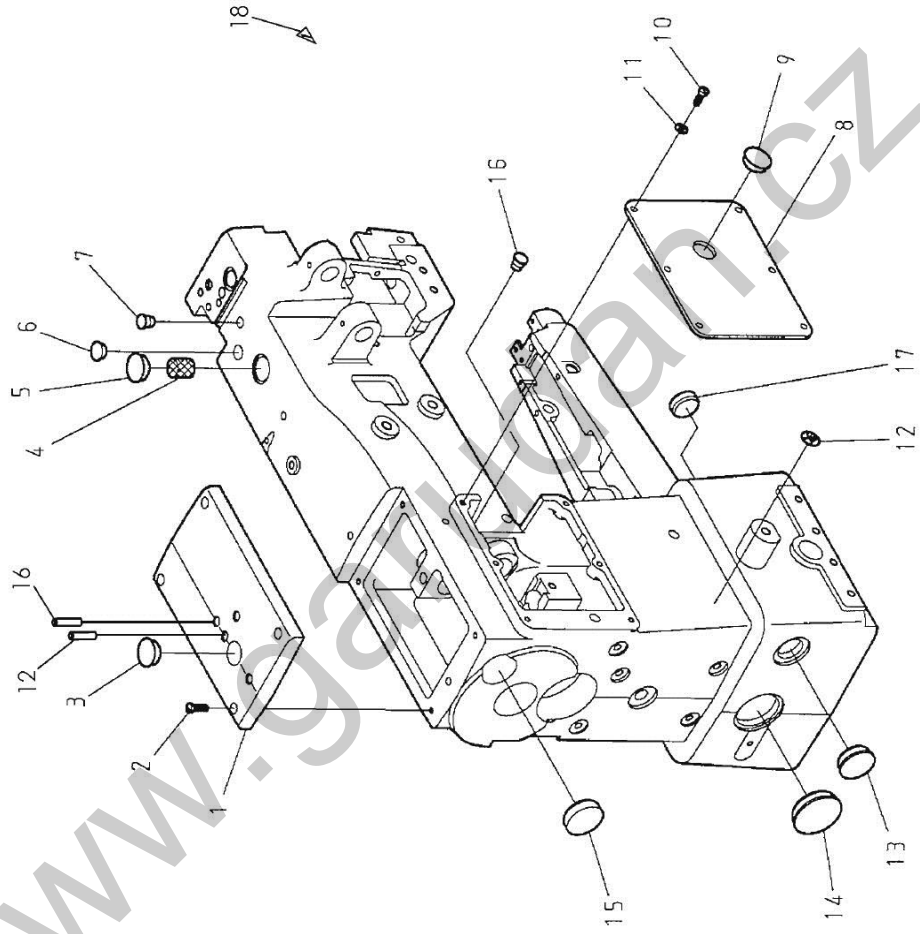

## A. FRAME &amp; MISCELLANEOUS COVER COMPONENTS (2/3)

REF.No	NOTE	Part No.	Name of Part	Remarks
1		8703110500	Top Cover Asm.	1
2		ZSB11017	Screw 11/64-40*12	4
3		A1013-0A	Rubber Plug	1
4		XB114001	Felt	1
5		A1013-0D	Rubber Plug	1
6		A1013-1A	Rubber Plug	1
7		6120117400	Rubber Plug	1
8		8703168000	Arm Side Cover	1
9		A1013-0A	Rubber Plug	1
10		ZSB11017	Screw 11/64-40*12	6
11		WA049003	Washer	6
12		YD060028	Pin	1
13		6120117300	Rubber Plug	1
14		6220117900	Rubber Plug	1
15		6120117000	Rubber Plug	1
16		YD060036	Pin	1
17		8710118400	Rubber Plug	1
18		WARN000108-A	Paster	1

A. FRAME & MISCELLANEOUS COVER COMPONENTS (3/3)

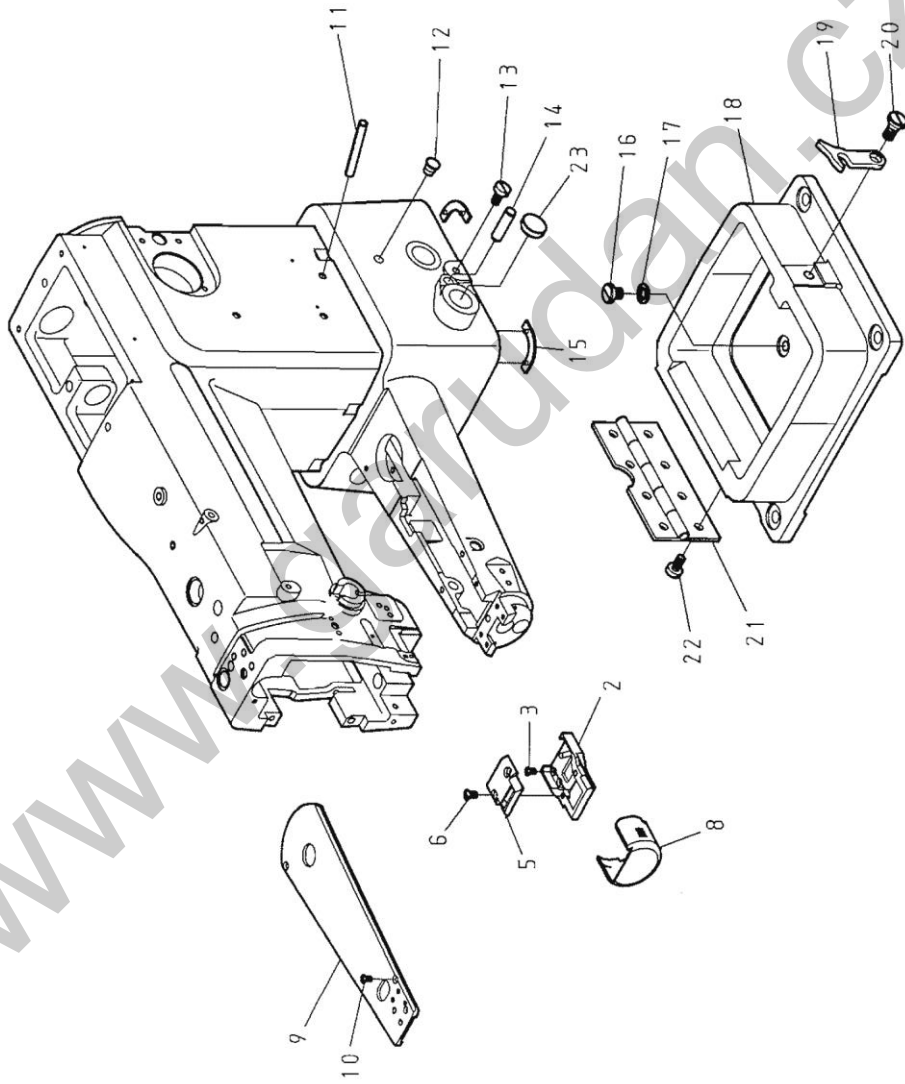

## A. FRAME &amp; MISCELLANEOUS COVER COMPONENTS (3/3)

REF.No	NOTE	Part No.	Name of Part	Remarks
2		87101106K0	Bed Cylinder Cap -----	1
3		ZSB09044	Screw 9/64-40*5.3 -----	4
5		8710111301	Throat Plate -----	1
6		ZSC11003	Screw 11/64-40*9 -----	2
8		6220183600	Hook Cover -----	1
9		8713110400	Cover -----	1
10		ZSC09012	Screw 9/64-40*7 -----	2
11		YD060056	Oil Pipe -----	1
12		6120117400	Rubber Plug -----	1
13		ZSB15034	Screw 15/64-28*12 -----	1
14		YA080280	Stopper Pin -----	1
15		6220119100	Vibration Preventing Rubber -----	2
16		ZSB20014	Screw 5/16-28*9.3 -----	1
17		EJ4109-0A	Spacer -----	1
18		8703110300	Machine Base -----	1
19		6220112700	Latch -----	1
20		ZSG20018	Hinge Screw -----	1
21		6220112800	Hinge -----	1
22		ZSB15034	Screw 15/64-28*12 -----	8
23	#01	6120117100	Rubber Plug -----	1

Note #01. . . . . Pedal Lifter Specification Parts



B. MAIN SHAFT & UPRIGHT SHAFT COMPONENTS

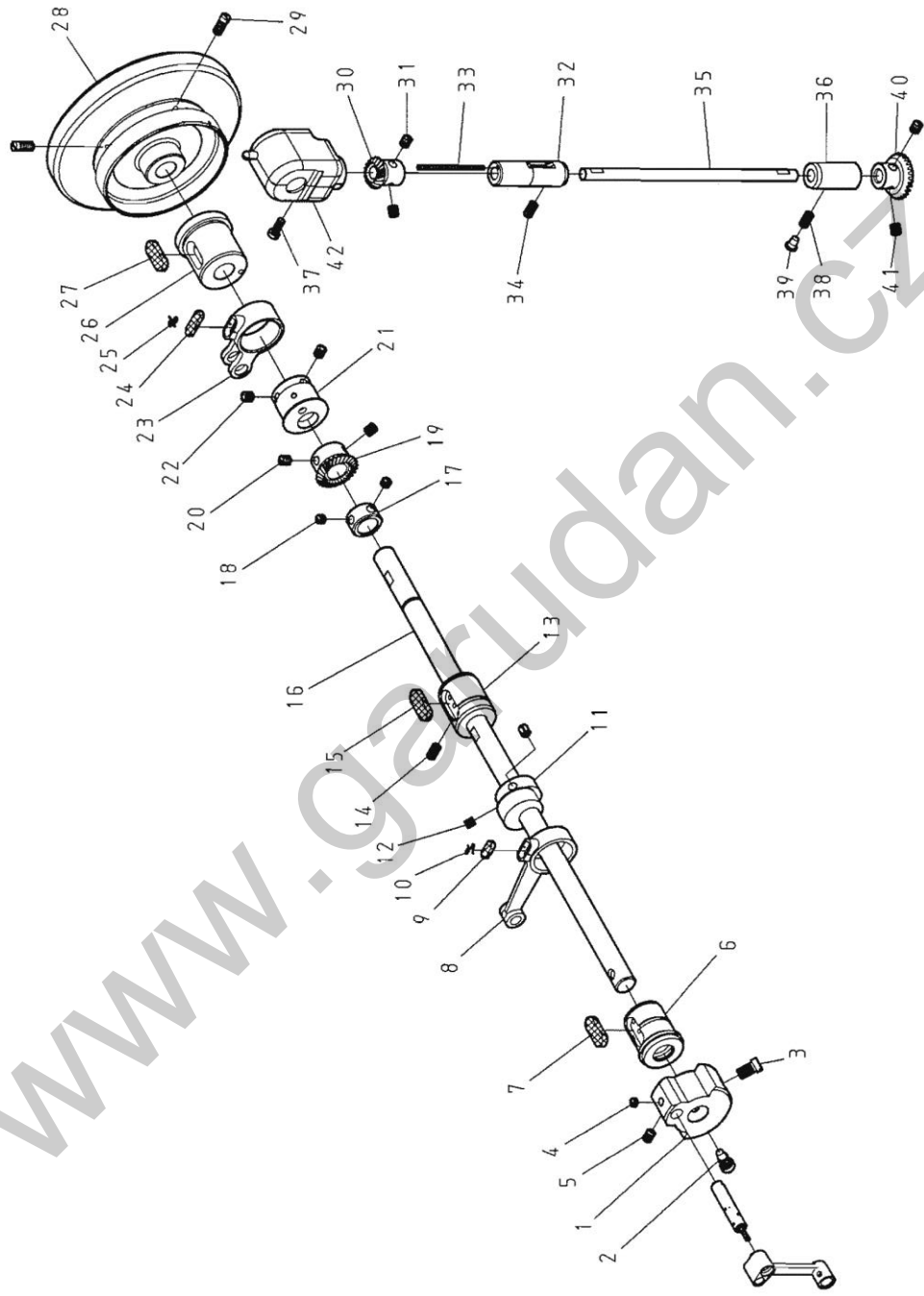

## B. MAIN SHAFT &amp; UPRIGHT SHAFT COMPONENTS

REF.No	NOTE	Part No.	Name of Part	Quantity	Remarks
1		8713120800	Counterweight	1	
2		ZSB18001	Screw 9/32-28*9.5	1	
3		ZSB18002	Screw 9/32-28*13	1	
4		ZSA15019	Screw 15/64-28*3	1	
5		ZSA15017	Screw 15/64-28*8.5	2	
6		8110120200	Main Shaft Bushing, Front	1	
7		XB210001	Felt	1	
8		8233144501	Connecting Rod	1	
9		XB207002	Felt	1	
10		A1130-0A	Spring	1	
11		823314400Q	Driving Cam	1	
12		ZSH16004	Screw 1/4-40*10	2	
13		8110120301	Main Shaft Bushing, Center	1	
14		ZSA15020	Screw 15/64-28*11	1	
15		XB210001	Felt	1	
16		8703120100	Main Shaft	1	
17		E4044-0A	Thrust Collar	1	
18		ZSA16010	Screw 1/4-40*4.5	2	
19		A1108-0C	Bevel Gear, Large	1	
20		ZSA16011	Screw 1/4-40*7	2	
21		6220122000	Feed Cam	1	
22		ZSH16001	Screw 1/4-40*6	2	
23		5371167400	Reverse Sewing Crank	1	
24		XB207001	Felt	1	
25		A1130-0A	Spring	1	
26		8110120400	Main Shaft Bushing, Rear	1	
27		XB210001	Felt	1	
28		6120120302	Hand Wheel	1	
29		ZSB15026	Screw 15/64-28*18	2	
30		A1109-0C	Bevel Gear, Small	1	
31		ZSA16011	Screw 1/4-40*7	2	
32		8110132100	Upright Shaft Bushing	1	
33		XA300055	Oil Wick	1	
34		ZSA15020	Screw 15/64-28*11	1	
35		8110132000	Upright Shaft	1	
36		A1113-0B	Upright Shaft Bushing	1	
37		ZSB12008	Screw 3/16-24*12	1	
38		ZSA15020	Screw 15/64-28*11	1	
39		A1013-1A	Rubber Plug	1	
40		A4020-0C	Bevel Gear, Large	1	
41		ZSA16011	Screw 1/4-40*7	2	
42		8703351005	Gear Case Cover	1	

C. NEEDLE BAR & THREAD TAKE-UP LEVER COMPONENTS

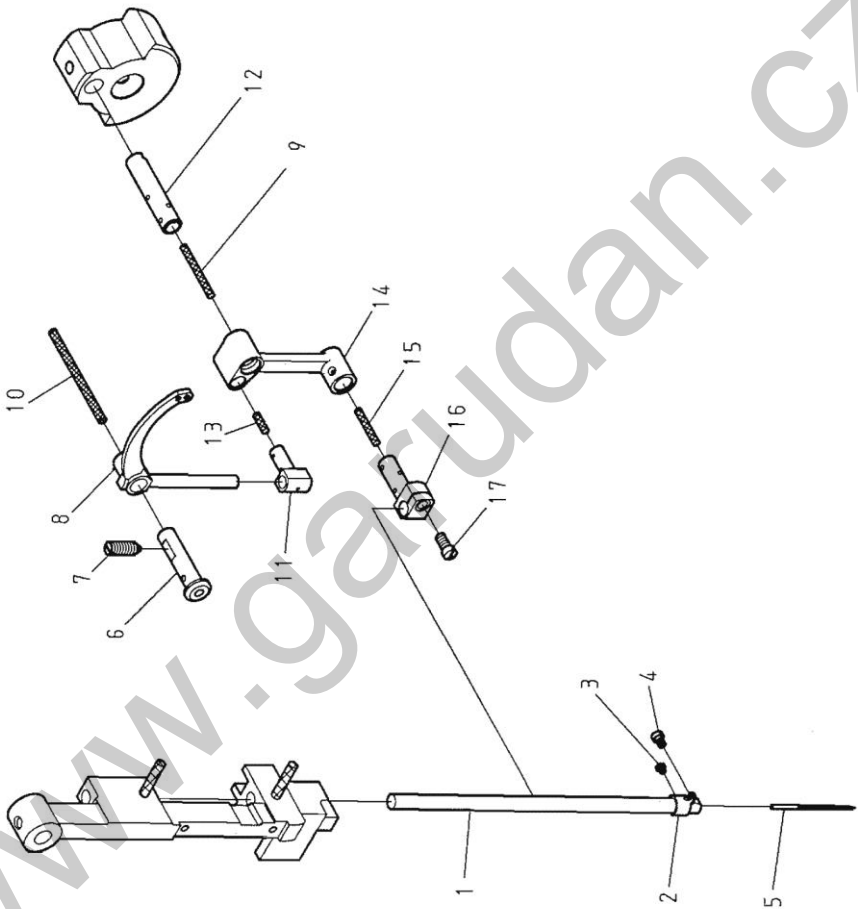

## C. NEEDLE BAR &amp; THREAD TAKE-UP LEVER COMPONENTS

REF.No	NOTE	Part No.	Name of Part	Remarks
1		Q1070-0A	Needle Bar -----	1
2		F1076-0A	Needle Bar Thread Guide -----	1
3		ZSB06002	Screw 3/32-56*2.5 -----	1
4		ZSB08002	Screw 1/8-44*4.5 -----	1
5		JNDP x 17-21	Needle DP x 17-21 -----	1
6		8703106100	Thread Take-up Lever Pin -----	1
7		ZSA15012	Screw 15/64-28*17 -----	1
8		8713190101	Thread Take-up Lever -----	1
9		XA300065	Oil Wick -----	1
10		XA200250	Oil Wick -----	1
11		8713190800Q	Thread Take-up Slide Brock -----	1
12		7162110700	Needle Bar Crank Shaft -----	1
13		XA300030	Oil Wick -----	1
14		8713190800Q	Needle Bar Crank Rod -----	1
15		XA300020	Oil Wick -----	1
16		B1074-0A	Needle Bar Connection -----	1
17		ZSB11003	Screw 11/64-40*9 -----	1

D. NEEDLE BAR ROCKING MOTION MECHANISM COMPONENTS

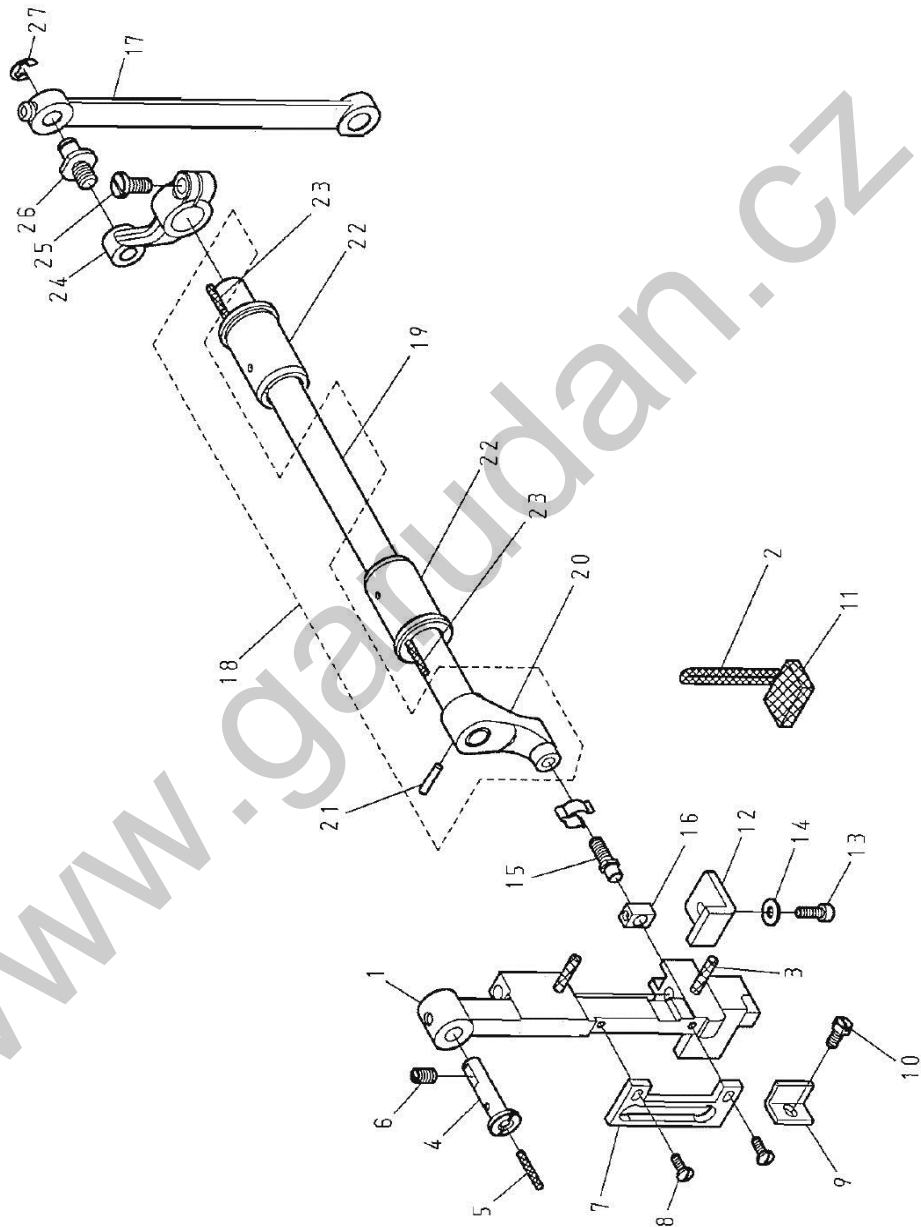

## D. NEEDLE BAR ROCKING MOTION MECHANISM COMPONENTS

REF.No	NOTE	Part No.	Name of Part	Remarks
1		8610270100	Needle Bar Guide Bracket	1
2		XA300125	Oil Wick	1
3		XA300040	Oil Wick	1
4		B1091-0A	Needle Bar Guide Bracket Stud	1
5		XA300020	Oil Wick	1
6		ZSA15023	Screw 15/64-28*10	1
7		B1285-0A	Vibrating Presser Bar Guide	1
8		ZSB09002	Screw 9/64-40*10	2
9		8713270500	Needle Bar Guide	1
10		ZSD11001	Screw 11/64-40*10	2
11		XB316001	Felt	1
12		8110270401	Needle Bar Guide	1
13		ZMJ04002	Screw M4 x 0.7*12	1
14		WA049005	Washer	1
15		B1333-0A	Crank Pin	1
16		B1334-0A	Square Block	1
17		8610271100	Connecting Rod	1
18		8110270814	Needle Bar Vibrating Shaft Ams.	1
19		8110270801	Needle Bar Vibrating Shaft	(1)
20		F1332-0A	Needle Bar Vibrating Crank (Left)	(1)
21		YB030020	Taper Pin $\phi 3*20*1/50$	(1)
22		8110272801	Needle Bar Vibrating Shaft Bushing	2
23		XA300040	Oil Wick	2
24		8710271000	Needle Bar Vibrating Crank (Right)	1
25		ZSB15009	Screw 15/64-28*13	1
26		Q4436-1A	Hinge Screw	1
27		RE000060	Retaining Rings- E Type 6	1

E. UPPER FEED MECHANISM COMPONENTS

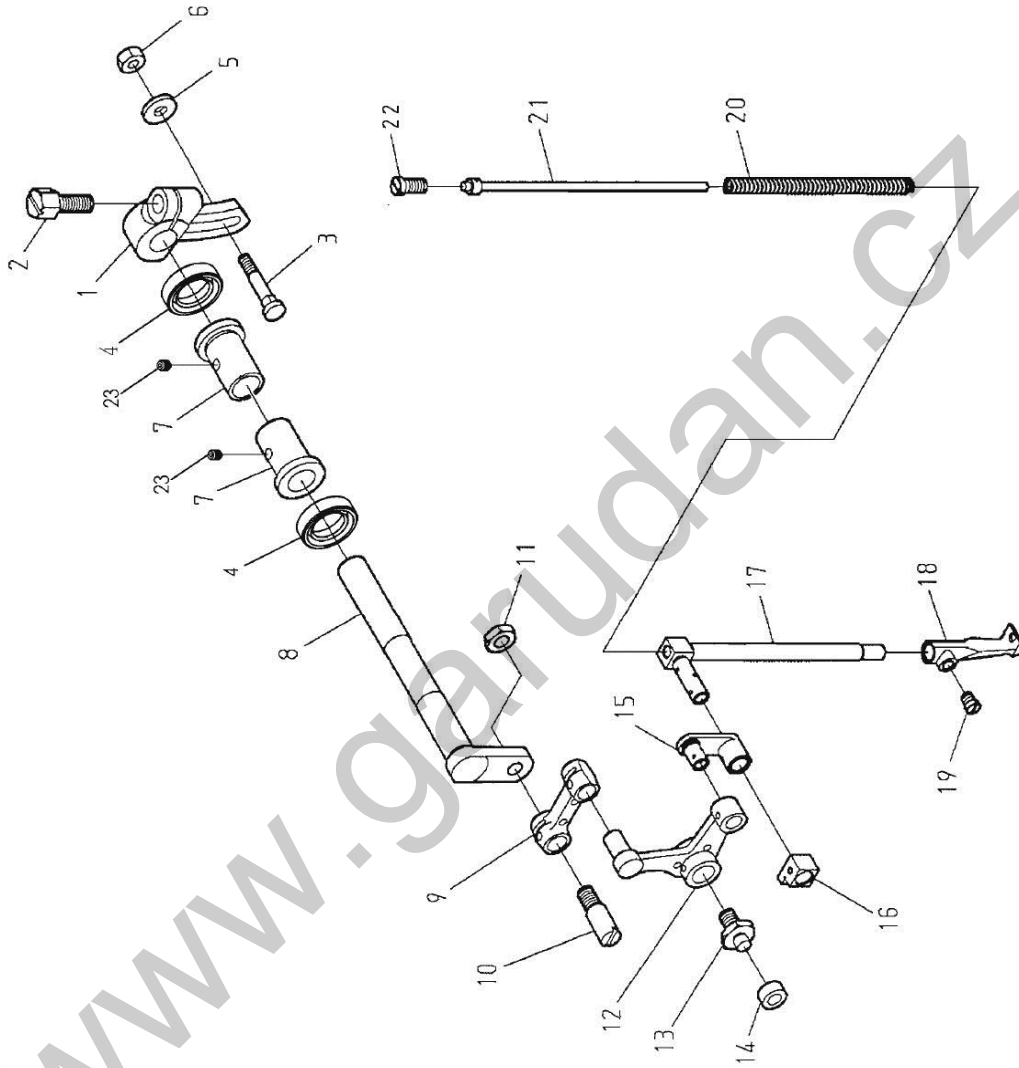

## E. UPPER FEED MECHANISM COMPONENTS

REF.No	NOTE	Part No.	Name of Part	Remarks
1		8233144702	Feed Rotating Shaft Crank	1
2		ZSD16007	Screw 1/4-28*16.5	1
3		ZMG06019	Screw	1
4		OAGM111503	Oil Seal	2
5		WH206009	Washer	1
6		ZML06001	Nut (M6 X 1.0)	1
7		8703145000	Feed Rotating Shaft Bushing	2
8		8233144801	Feed Rocker Shaft	1
9		8233145101	Lifting Bell Crank Link	1
10		ZSK16002	Hinge Screw	1
11		ZSL16001	Nut 1/4-32	1
12		8233143601	Lifting Bell Crank	1
13		8233152000	Pin	1
14		8233151900	Roller	1
15		B1283-0A	Vibrating Presser Bar Link	1
16		B1284-0A	Slide Brock	1
17		8703141700	Vibrating Presser Bar	1
18		8710151000	Walking Foot	1
19		ZSB11009	Screw 11/64-40*5	1
20		8230144203	Spring	1
21		B1280-0A	Vibrating Presser Spring Guide	1
22		ZSB20017	Screw 5/16-28*10	1
23		ZSA11012	Screw 11/64-40*6.5	2



F. PRESSURE BAR & KNEE LIFTER COMPONENTS (1/3)

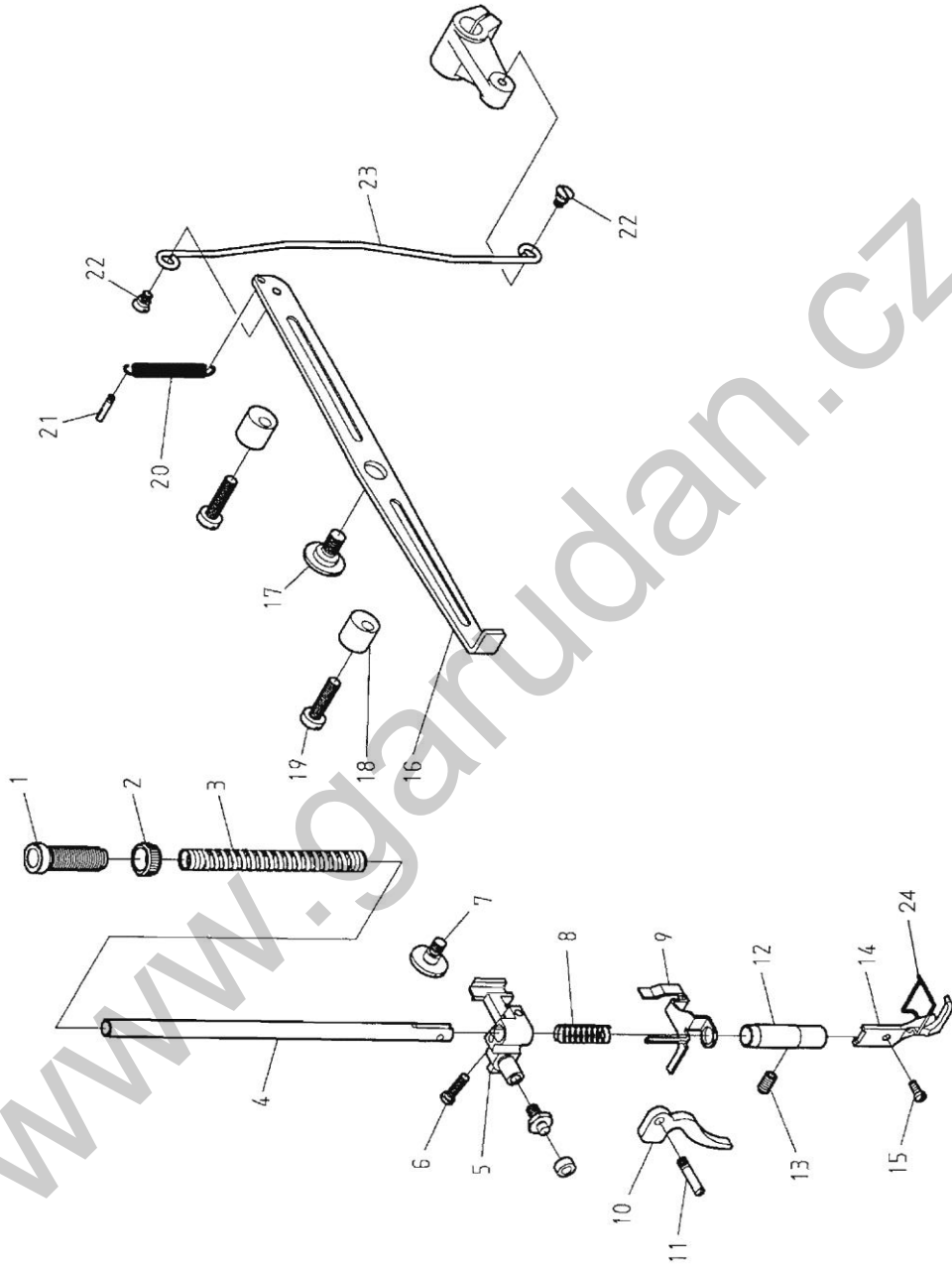

## F. PRESSURE BAR &amp; KNEE LIFTER COMPONENTS(1/3)

REF.No	NOTE	Part No.	Name of Part	Remarks
1		ZSF32001	Screw	1
2		ZSN32001	Nut	1
3		8230150401	Presser Spring	1
4		8703150100	Presser Bar	1
5		8233150500	Presser Bar Lifter	1
6		ZSB11086	Screw 11/64-40*18	1
7		ZSG16006	Hinge Screw	1
8		B1274-0A	Spring	1
9		8233344000	Tension Release Slide	1
10		EJ1200-0A	Presser Foot Lifter	1
11		ZSK12026	Hinge Screw	1
12		8233150200	Bushing	1
13		ZSA15020	Screw 15/64-28*11	1
14		8710153000	Presser Foot Asm.	1
15		ZSB09003	Screw 9/64-40*9	1
16		8233343000	Foot Lifter Lifting Lever	1
17		ZSG20004	Hinge Screw	1
18		8370341100	Stopper	2
19		ZSB16011	Screw 1/4-24*25	2
20		8230340200	Spring	1
21		EJ4434-2A	Spring Suspension	1
22		ZSK12003	Hinge Screw	2
23		8703340400	Knee Operating Connection Bar	1
24		8710152500	Spring	1

F. PRESSURE BAR & KNEE LIFTER COMPONENTS (2/3)

KNEE LIFTER SPECIFICATIONS

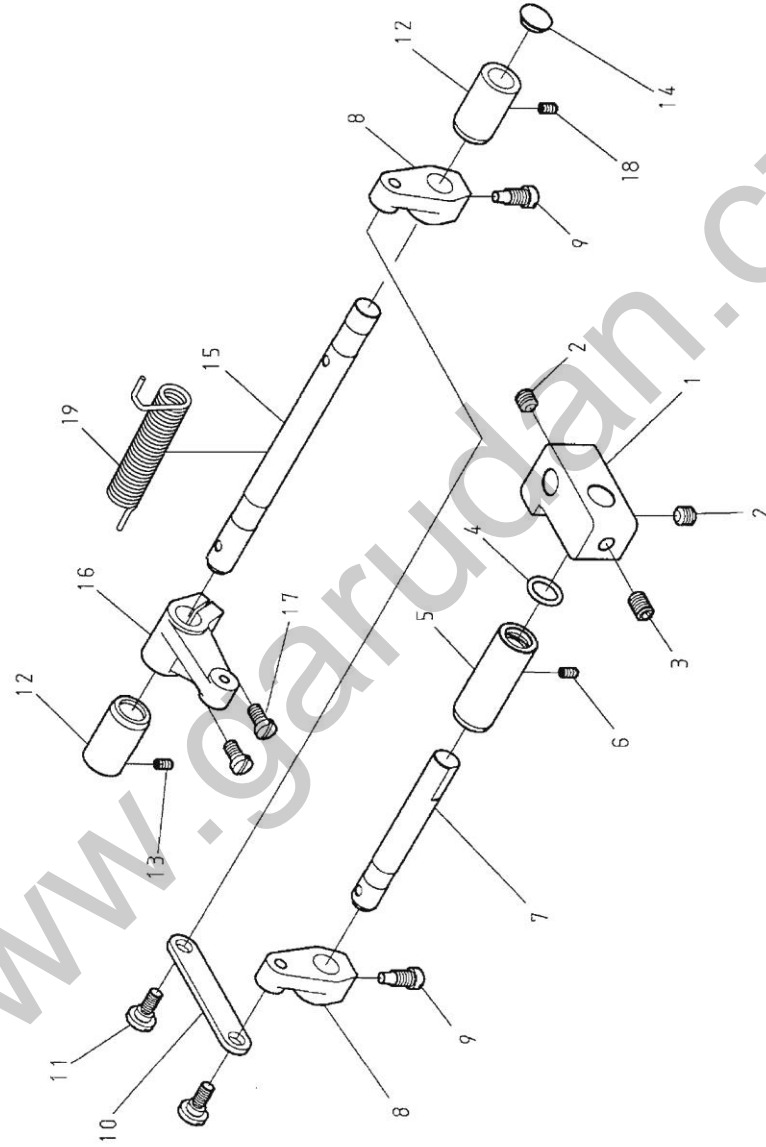

## F. PRESSURE BAR &amp; KNEE LIFTER COMPONENTS(2/3)

REF.No	NOTE	Part No.	Name of Part	Quantity	Remarks
1		6220342000	Knee Lifter Crank	1	
2		ZMH08003	Screw M8 × 1.25*8	2	
3		ZMH08002	Screw M8 × 1.25*12	1	
4		OPP01250	O-rings $\phi$ 12,5	1	
5		6220344200	Bushing	1	
6		ZSA11007	Screw 11/64-40*7	1	
7		6220342200	Shaft	1	
8		8703341600	Knee Lifter Crank	2	
9		ZSB18001	Screw 9/32-28*9,5	2	
10		8703343400	Knee Lifter Link	1	
11		ZSG15040	Hinge Screw	2	
12		8703343800	Bushing	2	
13		ZSA11007	Screw 11/64-40*7	1	
14		6220118100	Rubber Plug	2	
15		8703341701	Knee lifter shaft	1	
16		8703342900	Knee Lifter Crank (Rear)	1	
17		ZSB15028	Screw 15/64-28*11,5	2	
18		ZSA11004	Screw 11/64-28*3,5	1	
19		8703343900	Spring	1	

F. PRESSURE BAR & KNEE LIFTER COMPONENTS (3/3)

PEDAL LIFTER SPECIFICATIONS

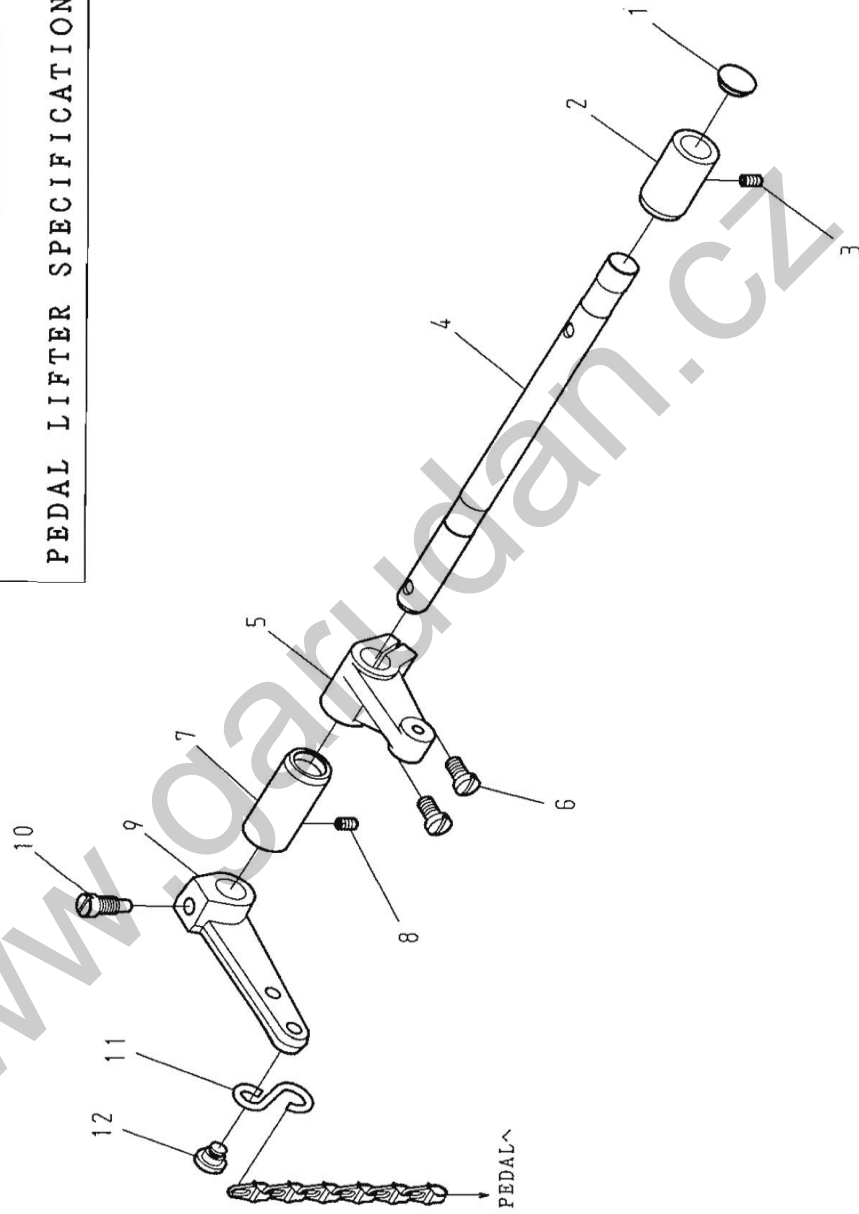

## F. PRESSURE BAR &amp; KNEE LIFTER COMPONENTS(3/3)

REF.No	NOTE	Part No.	Name of Part	Remarks
1	#01	6220118100	Rubber Plug -----	1
2	#01	8703343800	Bushing -----	1
3	#01	ZSA11007	Screw 11/64-40*7 -----	1
4	#01	8703341701	Knee lifter shaft -----	1
5	#01	8703342900	Knee Lifter Crank (Rear) -----	1
6	#01	ZSB15028	Screw 15/64-28*11,5 -----	2
7	#01	8703344200	Bushing -----	1
8	#01	ZSA11007	Screw 11/64-40*7 -----	1
9	#01	8703344400	Knee lifter Crank -----	1
10	#01	ZSB18001	Screw 9/32-28*9,5 -----	1
11	#01	4710340800	S-Plug -----	1
12	#01	ZSG16025	Hinge Screw -----	1

Note #01. . . . . Pedal Lifter Specification Parts

www.garudan.cz

G. LOWER FEED MECHANISM COMPONENTS (1/2)

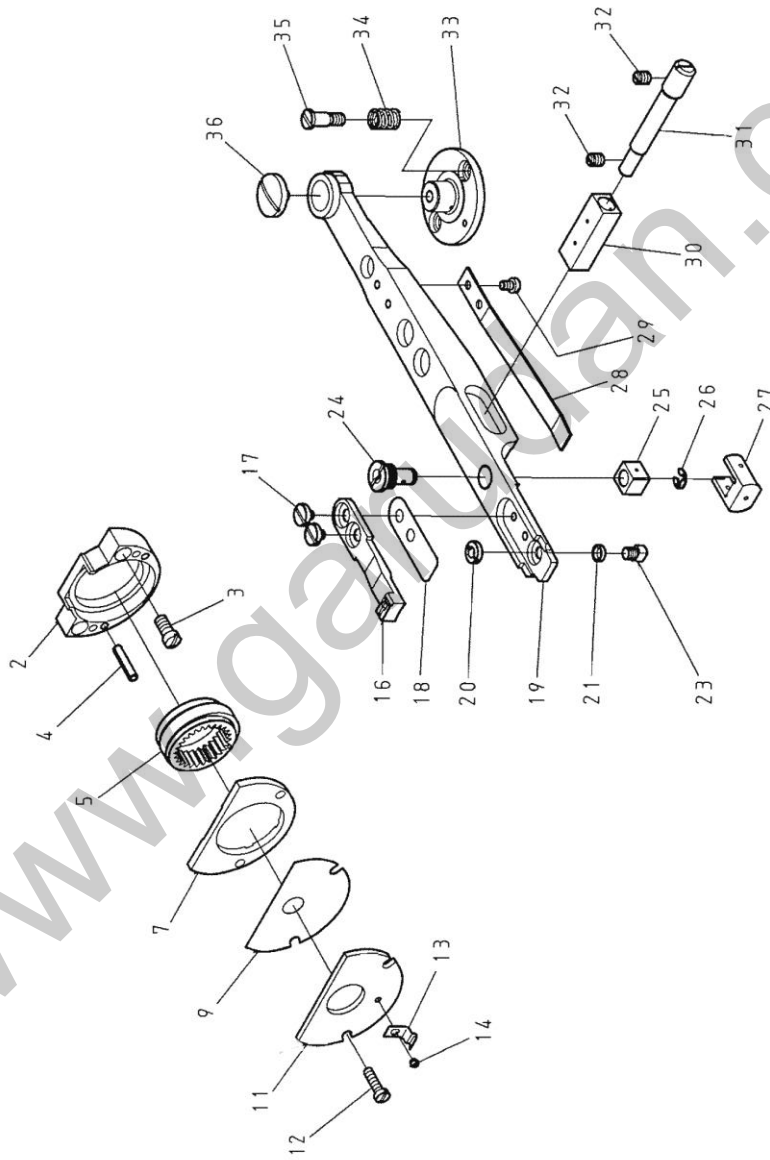

## G. LOWER FEED MECHANISM COMPONENTS(1/2)

REF.No	NOTE	Part No.	Name of Part	Quantity	Remarks
2		87101713K0	Feed Cam Holder B	1	
3		ZSB11051	Screw 11/64-40*11,5	2	
4		YD030015	Spring Pin 3.0X15	2	
5		6220170900	Feed Cam	1	
7		87101712K0	Feed Cam Holder A	1	
9		6220171400	Feed Cam Holder Washer	1	
11		6220171500	Feed Cam Holder Plate	1	
12		ZSB08016	Screw 1/8-44*12	2	
13		6220183700	Hook Cover Spring	1	
14		ZSB06004	Screw 3/32-56*2.2	1	
16		8710161402	Feed dog	1	
17		ZSB08041	Screw 1/8-44*4	2	
18		6220166100	Spacer	1	
19		62201601K0	Feed Bar	1	
20		87101716K0	Nut 11/64-40	1	
21		87101717K0	Washer	1	
23		87101711K0	Pin	1	
24		6220163300	Feed bar Slide Screw Stud	1	
25		6220169600	Feed bar Slide Block	1	
26		RE000030	E-Shaped Snap Rings (3mm)	1	
27		6220169700	Feed bar Slide Block A	1	
28		6220169800	Spring	1	
29		ZSB08010	Screw 1/8-44*4,6	2	
30		6220169500	Block	1	
31		6220164400	Eccentric Shaft	1	
32		ZSA11012	Screw 11/64-40*4,6	2	
33		6220169400	Feed bar Stud	1	
34		L6063-2A	Spring	2	
35		ZSG11028	Hinge Screw	2	
36		ZSB11047	Screw 11/64-40*5	1	



G. LOWER FEED MECHANISM COMPONENTS (2/2)

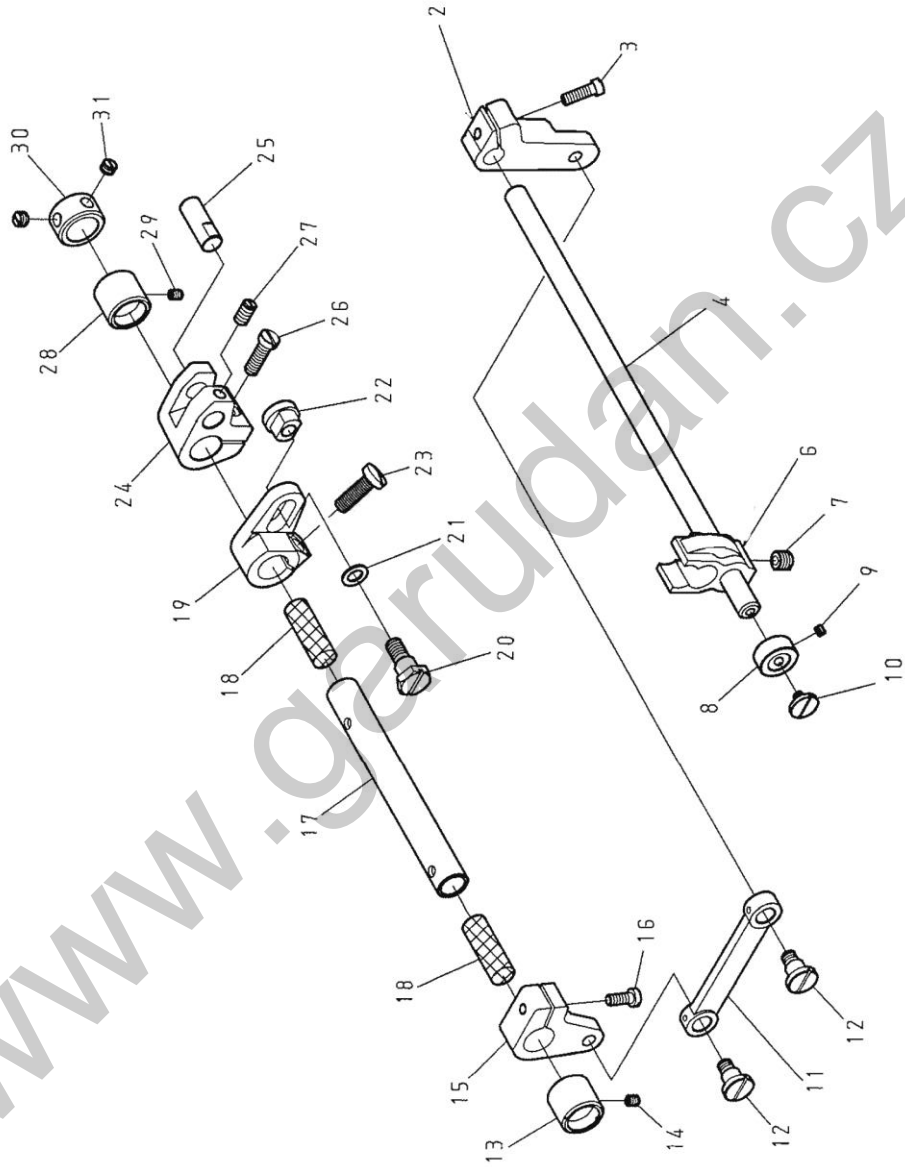

## G. LOWER FEED MECHANISM COMPONENTS(2/2)

REF.No	NOTE	Part No.	Name of Part	Remarks
2		6220169200	Feed Lifting Rock Link	1
3		ZSJ12009	Screw 3/16-28*15	1
4		8703160400	Feed Rocker Shaft	1
6		6220160500	Feed Bar Rod	1
7		ZSA20008	Screw 5/16-24*7	1
8		8360188200	Thrust Collar	1
9		ZSA11004	Screw 11/64-40*3,5	2
10		ZSB11069	Screw 11/64-40*6	1
11		6220165100	Rod	1
12		ZSG16016	Hinge Screw	2
13		6220167900	Bushing	1
14		ZSA11005	Screw 11/64-40*5,5	1
15		6220169300	Feed Lifting Rock Link	1
16		ZSJ12006	Screw 3/16-28*12	1
17		8710167800	Feed Rocker Shaft	1
18		XB111004	Felt	2
19		8710160800	Feed Connection Crank	1
20		ZSG18006	Hinge Screw	1
21		WA079008	Washer	1
22		ZSR18002	Nut	1
23		ZSB16005	Screw 1/4-24*20	1
24		6120160800	Feed Rocker Shaft Crank	1
25		8810167600	Horizontal Feed Rod Shaft	1
26		ZSB15032	Screw 15/64-28*14	1
27		ZSA15020	Screw 15/64-28*11	1
28		6220167900	Bushing	1
29		ZSA11005	Screw 11/64-40*5,5	1
30		E4044-0A	Thrust Collar	1
31		ZSA16010	Screw 1/4-40*4,5	2

H. FEED ADJUSTMENT MECHANISM COMPONENTS (1/2)

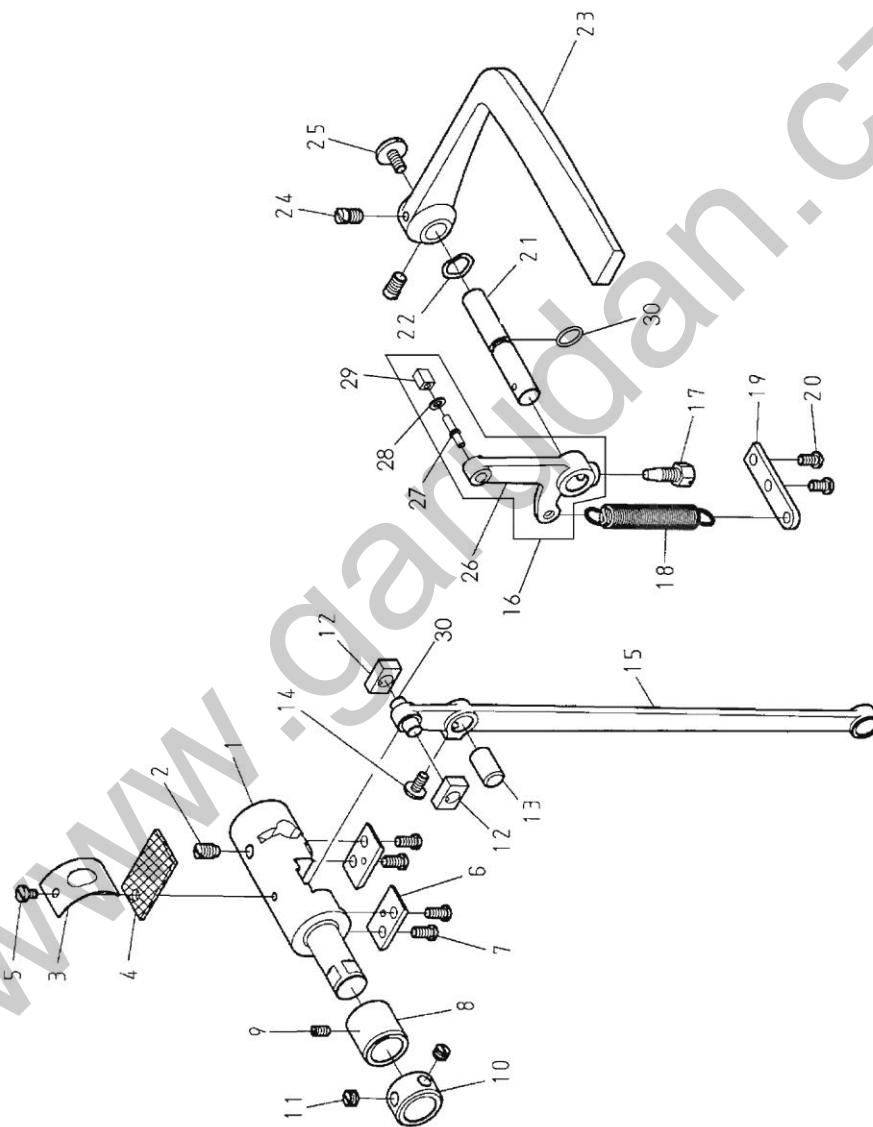

## H. FEED ADJUSTMENT MECHANISM COMPONENTS (1/2)

REF.No	NOTE	Part No.	Name of Part	Remarks
1		6120167000	Reverse Block	1
2		ZSA15037	Screw 15/64-28*10,5	1
3		5371353500	Plate	1
4		XB320003	Felt	1
5		ZSB09011	Screw 9/64-40*6,5	1
6		EJ4153-0A	Guide Plate	2
7		ZSB11018	Screw 11/64-40*9	4
8		6120160600	Bushing	1
9		ZSA11007	Screw 11/64-40*7	1
10		6120167200	Thrust Collar	1
11		ZSA16010	Screw 1/4-40*4,5	2
12		EJ4152-0A	Square Block	2
13		6120167500	Pin	1
14		ZSB11007	Screw 11/64-40*7	1
15		6120160900	Horizontal Feed Rod Com.	1
16		A1162-0A	Reverse Feed Crank Asm.	1
17		ZSD15003	Screw 15/64-28*16,5	1
18		A1166-0A	Spring	1
19		8703166000	Spring Suspension	1
20		ZSB11034	Screw 11/64-40*8	2
21		6120161800	Lever Shaft	1
22		WG000010	Washer	1
23		A1160-0A	Lever	1
24		ZSB15019	Screw 15/64-28*9	2
25		ZSB12011	Screw 3/16-28*10	1
26		A1163-0A	Reverse Feed Crank	1
27		A1165-0A	Shaft	1
28		WA040009	Washer	1
29		A1164-0A	Block	1
30		6120167100	Shaft	1
31		OPP00680	Ring	1

H. FEED ADJUSTMENT MECHANISM COMPONENTS (2/2)

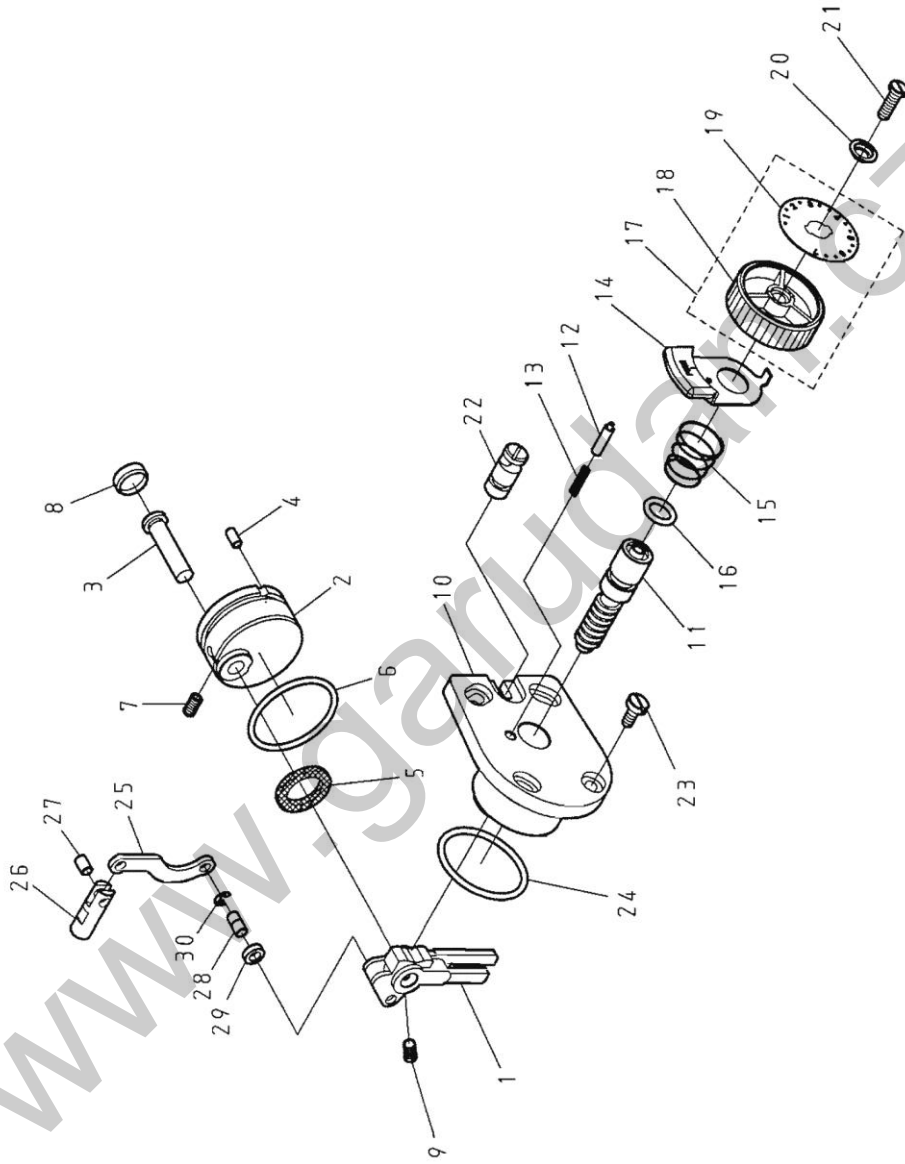

## H. FEED ADJUSTMENT MECHANISM COMPONENTS (2/2)

REF.No	NOTE	Part No.	Name of Part	Remarks
1		8610161100	Feed Regulator	1
2		8610162200	Bushing	1
3		6120161500	Feed Regurator Shaft	1
4		YA050100	Stopper Pin	1
5		XB120001	Felt	1
6		OPP04440	O-rings $\phi 44,4$	1
7		ZSA15020	Screw 15/64-28*11	1
8		8610118200	Rubber Plug	1
9		ZSB15006	Screw 15/64-28*8,5	1
10		6120162200	Stitch Dial Base	1
11		6120164300	Feed Regulating Screw	1
12		E1171-2A	Pin	1
13		E1158-0A	Spring	1
14		E1173-2A	Stopper Pin Releasing Lever	1
15		E1174-2A	Spring	1
16		OP00100A	O-rings $\phi 10$	1
17		8710164005	Dial Asm.	1
18		E1172-2B	Dial	(1)
19		8710164100	Dial plate	(1)
20		C1174-0A	Washer	1
21		ZSB12017	Screw 3/16-28*15	1
22		6120164400	Eccentric Pin	1
23		ZSB11026	Screw 11/64-40*10	4
24		OPP03550	O-rings $\phi 35,5$	1
25		8703168200	Feed Connecting Link	1
26		6120168300	Set Pin	1
27		6120168400	Pin	1
28		6120168500	Pin	1
29		WA060013	Washer	1
30		RE000040	E-Shaped Snap Rings (4mm)	1

I. HOOK DRIVE SHAFT COMPONENTS

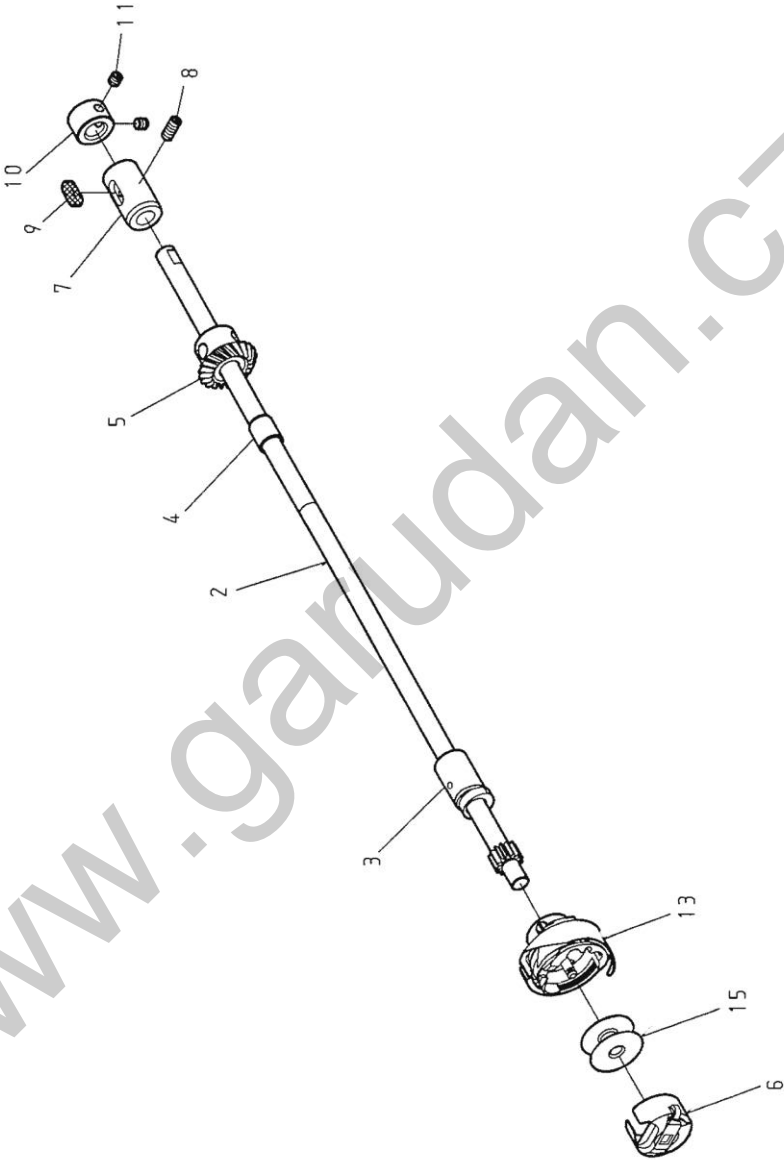

## I. HOOK DRIVE SHAFT COMPONENTS

REF.No	NOTE	Part No.	Name of Part	Quantity	Remarks
2		8713180100	Hook Driving Shaft -----	1	
3		8710180300	Bushing, Front -----	1	
4		6220180400	Bushing, Center -----	1	
5		A4021-0A	Screw Gear, Back -----	1	
6		Q6105-1A	Bobbin Case -----	1	
7		8703180500	Bushing, Rear -----	1	
8		ZSA11016	Screw 11/64-40*11 -----	1	
9		XB205002	Felt -----	1	
10		E4014-0A	Thrust Collar -----	1	
11		ZSA11011	Screw 11/64-40*4,5 -----	2	
13		Q6100-1A	Hook -----	1	
15		E7006-1A	Bobbin -----	1	

www.garudan.cz



J. UPPER THREAD TENSION REGULATOR MECHANISM COMPONENTS

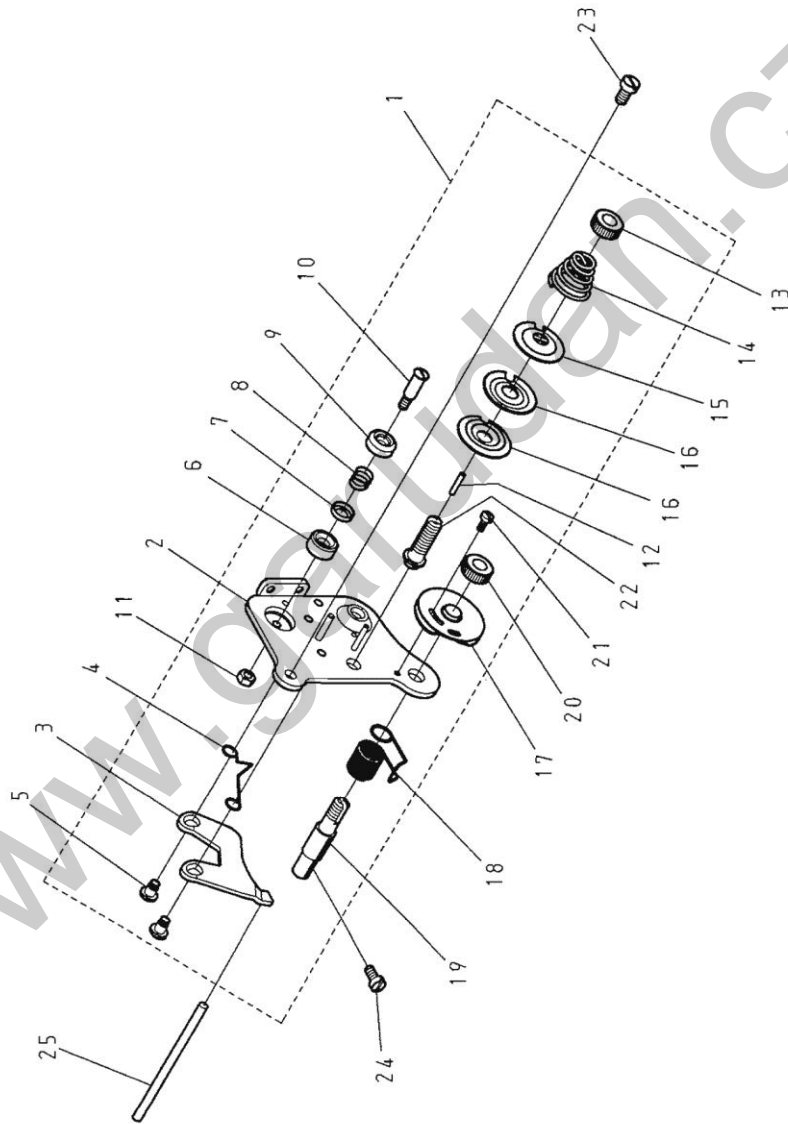

## J. UPPER THREAD TENSION REGULATOR MECHANISM COMPONENTS

REF.No	NOTE	Part No.	Name of Part	Remarks
1		EJ1020-0A	Thread Tension Regulator Asm. -----	1
2		A1038-0A	Mounting Plate Asm. -----	(1)
3		EJ1037-0A	Tension Releasing Plate -----	(1)
4		A1038-0A	Tension Releasing Spring -----	(1)
5		ZSG09004	Hinge Screw -----	(2)
6		A1030-0A	Thread Guide Disk -----	(1)
7		A1031-0A	Thread Guide Disk -----	(1)
8		A1032-0A	Spring -----	(1)
9		A1033-0A	Thread Guide Bracket -----	(1)
10		ZSG09005	Hinge Screw -----	(1)
11		ZSL09001	Nut 9/64-40 -----	(1)
12		EJ1028-0A	Tension Releasing Pin (small) -----	(1)
13		ZSN16002	Tension Thumb Nut 1/4-40 -----	(1)
14		EJ1021-0A	Tension Spring -----	(1)
15		A1034-0A	Tension Regulator Presser Disk -----	(1)
16		A1035-0A	Tension Regulator Disk -----	(2)
17		A1024-1A	Tension Controller Disk Set -----	(1)
18		EJ1027-0A	Thread Take-up Spring -----	(1)
19		EJ1026-0A	Tension Stud -----	(1)
20		ZSN16002	Tension Thumb Nut 1/4-40 -----	(1)
21		ZSB05001	Screw 3/32-56*6 -----	(1)
22		A1026-1A	Shread Tension Stud -----	(1)
23		ZSB11012	Screw 11/64-40*8 -----	1
24		ZSB09007	Screw 9/64-40*7,5 -----	1
25		8233312200	Tension Releasing Pin -----	1







## K. ACCESSORIES

REF.No	NOTE	Part No.	Name of Part	Remarks
1		C7001-0A	Cover	1
2		A7000-0A	Accessory Box	1
3		A7010-0A	Screw Driver (small)	1
4		A7010-1A	Screw Driver (middle)	1
5		A7010-2A	Screw Driver (Large)	1
6		INDP × 17-21	Needle DP × 17-21	4
7		A7012-1A	Oiler	1
8		A7012-2A	Oil Can	1
10		E7006-1A	Bobbin	4
11		ZMQ08001	Screw M8 × 1.25*65	4
12		WA089001	Washer	4
13		ZML08001	Nut M8 × 1.25	4
14		ZSB11011	Screw 11/64-40*9	1
15		6120914005	Ground Wire Asm.	1
16		6220119000	Head Rest Wood	1
17	#01	6220344700	Knee Lever Rod	1
18	#01	6220341900	Knee Lever Rod	1
19	#01	A7034-0A	Knee Lifter Crank	1
20	#01	ZSD20007	Screw 5/16-18*16	2
21		J7050-0A-A	Thread Stand	1
22		A7040-0C	Bobbin Winder	1
23		ZMT05001	Wood Screw	2
24		WA059003	Washer	2
25		8230335101	Belt Cover A	1
26		8230335201	Belt Cover B	1
27		8230335502	Belt Cover C	1
28		8230335801	Belt Cover D	1
29		6220335300	Belt Cover Stud (A)	3
30		8110335700	Belt Cover Stud (B)	1
31		ZSB11041	Screw 11/64-40*7	4
32		ZMT05003	Wood Screw	2
33		WA059003	Washer	2
34		ZMB04009	Screw M4 × 0.7*6	8
35		6220913500	Vibration Preventing Rubber	2
36	#01	A7037-0A	Knee Guird	1
37	#01	A7037-1A	Knee Plate	1
38	#01	A7036-0A	Retainer	1
39	#01	ZSD15007	Screw 15/64-28*14	1
40		87109133K0	Screw Driver	1
41	#02	B7060-0A	Chain Assy.	1
42		A7010-0Z	Screw Driver Asm.	1
43		5100342000	Knee Lifter Crank	1

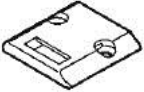
Note #01. . . . . Knee Lifter Specification Parts  
#02. . . . . Pedal Lifter Specification Parts

## L. GAUGE PARTS LIST

THROAT PLATE	
	8710111301
FEED DOG	
	8710161402
WALKING FOOT	
	8710151000
PRESSUER FOOT	 8710153000
	8710152500
	8710153004